

AT8657/LED

Flush-mount Microphone Socket with LED Ring and Touch Switch



Features

- Flush-mount microphone socket for the ES945/ES947 or any phantom-powered gooseneck with a 3-pin XLRM-type output and a base diameter no greater than 21mm
- Mounts unobtrusively in tabletops
- Switch logic output permits control of remote devices from builtin capacitance switch
- Integral, phantom-powered, Red/Green LED indicator ring
- Operates on 24-48V DC phantom power
- 3-pin XLRF-type connector for microphone, 5-pin XLRM-type connector for output
- Lock tab in socket case automatically locks microphone in place, holding it there until tab is manually released by user
- Isolators provide mechanical dampening of mounting-surface vibration
- Low-profile design with low-reflectance black finish for minimum visibility

Description

The AT8657/LED flush-mount microphone socket features a capacitive-type touch-sensitive switch, Red/Green LED indicator ring, switch logic output for controlling remote devices and a lock tab to hold microphone in place. The socket is equipped with a three-pin XLRF-type in, and a five-pin XLRM-type output connector.

The AT8657/LED requires 24-48V DC phantom power for operation. The electronics in the socket take up to 30 seconds to stabilize after power is applied; during this start-up period, some sonic disturbances may be heard upon switching if the system is "live."

The touch-sensitive switch can be used to trigger an external device.

The lock tab, located in the socket case, automatically engages when microphone is inserted, securely holding it in place until tab is manually released by user.

The output of the socket is a 5-pin XLRM-type connector.

Isolators are included with the unit for mechanical isolation from the mounting surface. A retaining ring is also included for use with gooseneck microphones. The socket is enclosed in a heavy-duty die-cast case. The low-profile housing has a low-reflectance black finish.

Installation and Operation

The AT8657/LED requires 24-48V DC phantom power for operation.

Output is low impedance (Lo-Z) balanced. The signal appears across Pins 2 and 3; Pin 1 is ground (shield). Output phase is "Pin 2 hot" - positive acoustic pressure produces positive voltage at Pin 2. Switch logic output appears between pins 1 and 4. LED logic input appears between pins 1 and 5.

GENUINE
ACCESSORIES

The microphone socket should be installed on a flat, unobstructed mounting surface.

The AT8657/LED should be mounted to a tabletop using the included isolators in order to dampen surface vibration. To mount the socket with the isolators, a 35 mm hole is recommended. Place the isolators on either side of the hole to achieve mechanical isolation from the mounting surface.

Use the retaining ring to hold a gooseneck microphone securely in the socket. Insert the microphone and plug it into the three-pin XLRF-type input, then slip the rubber isolator and retaining ring over the microphone and screw it in place at the microphone's base using included screws. **Note:** The retaining ring and gooseneck isolator are used only with gooseneck microphones.

The AT8657/LED's capacitive-type touch-sensitive switch allows the user to trigger a function on an external device: Switch logic output is High (+5V DC) when pressed. Low (0V DC) when not pressed.

The LED indicator ring lights red when logic high (+5V DC) and green when logic low (0V DC).

Avoid leaving the microphone in the open sun or in areas where temperatures exceed 43°C for long periods of time. Extremely high humidity should also be avoided.

Specifications

Output impedance	360 Ohms
Switch logic	High (+5V DC) when pressed; Low (0V DC) when not pressed
I/O voltage	-0.5V to 5.5V
LED input	Red when high (+5V DC), Green when low (0V DC), Maximum input voltage -0.5V to 5.5V
Phantom power requirements	24-48V DC, 4 mA typical
Switch	Touch-sensitive control : momentary
Weight	165 g
Dimensions	130.6 mm long, 55.0 mm maximum width
Input connector	3-pin XLRF-type
Output connector	5-pin XLRM-type
Accessories furnished	One pair isolators, one set metal retaining ring

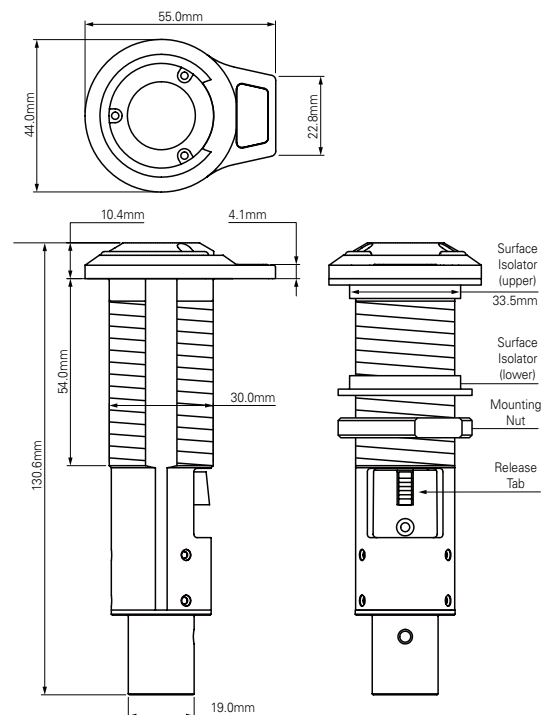

Pin-out Configuration

- PIN 1 - Ground
- PIN 2 - Audio +
- PIN 3 - Audio -
- PIN 4 - Switch Logic
- PIN 5 - LED Input

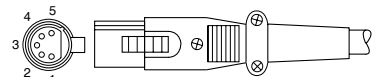

 **audio-technica**
Machida • Tokyo • Japan

FORM No. ATGC-L0321-14-E

AT8657/LED

嵌入式话筒插座 (带轻触开关及LED指示灯环)

GENUINE
ACCESSORIES



特点

- 嵌入式安装的话筒插座, 适用于 **ES945/ES947** 或任何使用**3针卡农公头**输出的**21mm**鹅颈式幻象供电话筒
- 用于桌面上的不显眼安装
- 设有轻触式按钮, 能经内置开关作远程设备的逻辑控制
- 整合环型 **LED** 状态显示灯, 以幻象供电操作, 提供绿色/红色显示
- 以 **24-48V** 幻象供电操作
- 以**3针卡农母头**连接话筒, 及**5针卡农公头**输出
- 插入话筒到位后, 能自动锁定话筒, 以避免随便被人拿取。只能在用户作手动释放后, 方能除下话筒
- 配有防震橡胶隔离环和金属固定环 (配合鹅颈话筒使用), 以减低安装面上的震动噪声
- 不显眼的低剖面设计, 表面涂上低反光黑色涂层。

AT8657/LED是一套嵌入式, 用于桌面安装设计的话筒插座, 具有轻触式开关作外部设备控制, 另外整合了一个环型LED状态显示灯, 能由外部控制绿色或红色的灯号显示。该插座还具有自动锁定话筒开关, 输入端为3针卡农母座; 而输出端为5针卡农公头。

插座需要直流24V至48V幻象供电工作, 插座中的电子电路在通电后需经30秒才能稳定; 在这初段时期, 如果在系统上开关按钮, 可能会听些声波的干扰。

轻触式的开关功能, 配有一个可编程的电容式轻触开关作远程设备的控制, 使用用户只需触摸按钮, 便可以轻松地控制外部设备。

该插座还具有锁定开关, 当话筒完全插入时可以自动锁定话筒, 以避免被人拿取, 只有作出手动释放后, 方能除下话筒。

插座输出端为5针XLRM卡农插头。

每个插座都配有一对防震橡胶隔离环和一套金属固定环 (配合鹅颈话筒使用), 以减低安装面上的震动噪声。外壳为全金属结构, 表面涂上低反光黑色涂层。

安装与操作

AT8657/LED 内置的控制电路, 需使用直流24V至48V幻象供电工作。

低阻抗的平衡音频输出, 音频信号以卡农公头的2号及3号针脚输出, 而1号针脚则为地线(屏蔽)连接。输出相位将以正相位电平设于2号针脚上。开关按钮的逻辑输出连接于1号与4号针脚中, 而LED输入控制则应用于1号与5号针脚中。

话筒插座应安装在一个平直及无阻碍物的平面上。

AT8657/LED 插座应使用附属的防震胶安装于桌面上, 以隔离桌面上震动。在与防震胶一起安装时, 需要开出直径35mm的圆孔, 而防震胶需要前后两端同时安装于平面上。

使用附带的金属固定环来安装鹅颈式话筒。把鹅颈式话筒插进插座后, 插座会自动锁定话筒, 再把固定环连带橡胶隔离垫圈套入话筒。小心放下并对准三个小孔位置, 并用附带的螺丝安装收紧。如要卸下话筒, 必须先松开螺丝。然后取出固定环及橡胶隔离垫圈。按下插座下方的释放解锁键, 小心把话筒拔出。**注意:** 金属固定环只适用于鹅颈式话筒安装。

AT8657/LED 插座的电容式轻触开关, 可容许使用者用于控制外部的其他设备: 当按下时, 开关逻辑输出为高电位(直流+5V); 而无按下时, 为低电位(直流0V)的开关逻辑输出。

LED显示灯在高电位输入时(直流+5V)为红色; 低电位输入时(直流0V)为绿色

把话筒暴露于高温中可能导致输出电平逐渐及永久减弱, 应避免将话筒留在日晒或长时间置于温度超过43°C的地方, 而极高湿度也应避免。

技术指标

输出阻抗	360 欧姆
开关逻辑控制	按下时为高电位 (直流+5V); 无按下时为低电位 (直流0V)
输入/输出电压	-0.5V 至 5.5V
LED显示灯	高电位 (直流+5V)为红色 / 低电位 (直流0V)为绿色
最高输入电压	-0.5V 至 5.5V
幻象供电	直流 24-48V, 耗电 4 mA 典型
开关	轻触式控制式: 瞬时式
重量	165 克
外形尺寸	长 128.2 mm, 最大宽度 55.3 mm
输入端子	3 针卡农母头
输出端子	5 针卡农公头
标准配置	1对防震绝缘胶; 1套金属固定环

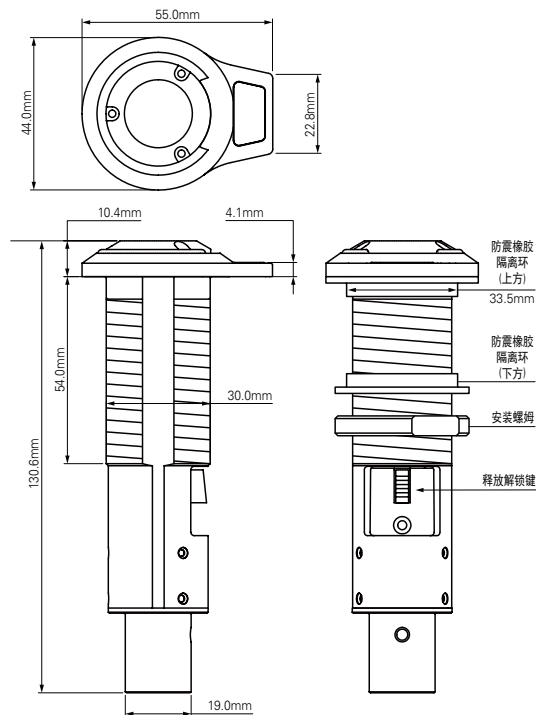

卡农母头接线说明

- 接点1 - 地线
- 接点2 - 音频正相位电平 (+)
- 接点3 - 音频反相位电平 (-)
- 接点4 - 开关逻辑输出
- 接点5 - LED 显示控制输入

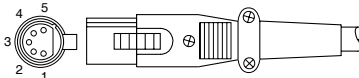

audio-technica 鐵三角
Machida · Tokyo · Japan

FORM No. ATGC-L0321-14-C